



TYPE: BP16EF



BP16EF Current Output Pressure Transmitter

Description

The BP16EF range of pressure transmitters combine the excellent performance of bonded foil strain gauge technology with a single piece stainless steel diaphragm construction. They provide a cost effective price/performance ratio and are suitable for use in many arduous measurement applications, with integral signal conditioning providing an amplified current output.

The BP16EF construction makes it ideal for a wide range of applications, including hydraulic lifting, mobile hydraulic vehicles, portable test gear and air frame test rigs amongst others.

The most popular version of the BP16EF is the integral cable version, which is supplied with a 2 metre PVC cable. An integral connector version is also available, as are versions with different cable lengths or different cable types.

The BP16 family of products offer a variety of amplified output formats (see the BP16 and BP16UVW data sheets). We can supply the BP16EF on its own or integrated with any of the wide range of instrumentation available from LCM Systems.

Features

- Ranges from 100psig to 15,000psig
- Stainless steel diaphragm (single piece construction)
- 1/4" BSPP female pressure port (supplied as standard with bonded seal and 1/4" male pressure port adaptor)
- 2-wire or 3-wire 4-20mA output
- Amplified voltage output version (refer to BP16UVW data sheet)
- mV/V Wheatstone Bridge version available (refer to BP16 data sheet)

Typical Applications

- On-board vehicle weighing
- Earthmoving vehicle hydraulic system protection/weighing
- Portable hydraulic test sets
- Air frame test rigs
- Hydraulic system feedback control

Specification

Pressure Range (psig)	100, 150, 200, 500, 1000, 2000, 3000, 5000, 10,000, 15,000
Over pressure range	150% with $\leq \pm 1\%$ calibration shift (125% with 15,000psi version)
Burst pressure	400% (200% for 15,000psi version)
Output Signal	BP16E: 2 wire 4-20mA (16mA span, $\pm 0.1\%$ tolerance) BP16F: 3 wire 4-20mA (16mA span, $\pm 0.1\%$ tolerance)
Zero offset	$\leq \pm 1\%$ of full scale output (FSO)
Accuracy	$\leq \pm 0.1\%$ FSO ($\pm 0.7\%$ for 100-200psi versions)
Repeatability	$\leq \pm 0.1\%$ FSO
Supply voltage	BP16E: 7.5vdc to 28vdc BP16F: 10vdc to 28vdc
Maximum output load	BP16E: 800ohms at 28vdc BP16F: 250ohms at 28vdc
Operating temperature range	-20 to +70°C
Compensated temperature range	+10 to +60°C
Zero temperature coefficient	$\leq \pm 0.03\%$ of FSO/°C ($\leq \pm 0.01\%$ FSO/°C optional)
Span temperature coefficient	$\leq \pm 0.03\%$ of FSO/°C ($\leq \pm 0.01\%$ FSO/°C optional)
Environmental protection level	IP66
Connection type	2 metre 4 core screened PUR cable or 4 pin Lumberg connector (c/w 5m PUR cable assembly)
Wiring connections	BP16E: +supply Red (Pin 1) -supply Blue (Pin 2) BP16F: +supply Red (Pin 1) -supply/-signal Blue (Pin 2) +signal Green (Pin 3)

Available Options

- Integral connector option
- Modified cable length/type options
- TEDS option (when used with TR150 handheld display)
- Other special versions available

BP16EF Current Output Pressure Transmitter

Dimensions

Integral Cable Version

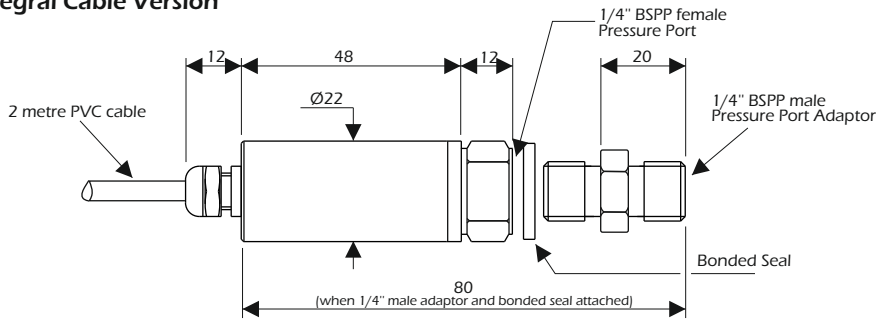

Integral Connector Version

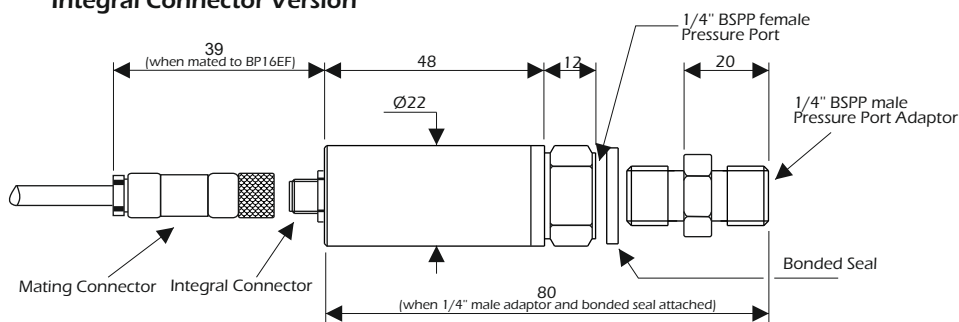

All dimensions are in mm

Rating (psi)	Weight (g)	Resolution (psi)
100	50	0.5
150	50	0.5
200	50	1
500	50	0.5
1000	50	1
2000	50	2
3000	50	2
5000	50	5
10000	50	10
15000	50	10

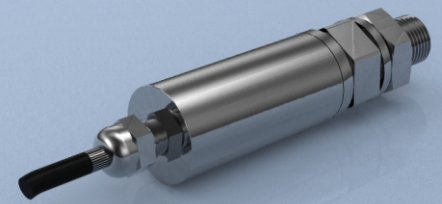

www.lcmsystems.com

LCM Systems Ltd

Unit 15, Newport Business Park, Barry Way
Newport, Isle of Wight PO30 5GY UK
Tel: +44 (0)1983 249264
sales@lcmsystems.com
www.lcmsystems.com

LCM Systems (România)

Strada Ștefan Cel Mare 26a,
Tunari, cod.077180, Ilfov, România
Tel: +40 (0)77 4641899
ro@lcmsystems.com
www.lcmsystems.ro

Due to continual product development, LCM Systems Ltd reserves the right to alter product specifications without prior notice.



SCIGATE AUTOMATION (S) PTE LTD

No 1 Bukit Batok Street 22 #01-01 Singapore 659592
Tel: (65) 6561 0488 Fax: (65) 6561 0588
Email: sales@scigate.com.sg Web: https://scigate.com.sg/

Business Hours: Monday - Friday 8:30AM - 6:15PM

Issue No. 2

Issue date: 14/11/2016

APPROVED

(unapproved if printed)